

**Valves series A1**  
1/8", 5/2 - 5/3, electrically operated

**Standard executions**

Version	Symbol	Code	Item
5/2 solenoid/spring		034011	A1E150
5/2 solenoid/solenoid		034021	A1E151
5/3 with closed centres		034031	A1E170
5/3 with open centres		034033	A1E171
5/3 with pressurised centres		034032	A1E172
5/2 solenoid/spring, external air pilot		034012	A1K150
5/2 solenoid/solenoid external air pilot		034008	A1K151
5/3 with closed centres, external air pilot		034009	A1K170
5/3 with open centres, external air pilot		034010	A1K171
5/3 with pressurised centres, external air pilot		034013	A1K172

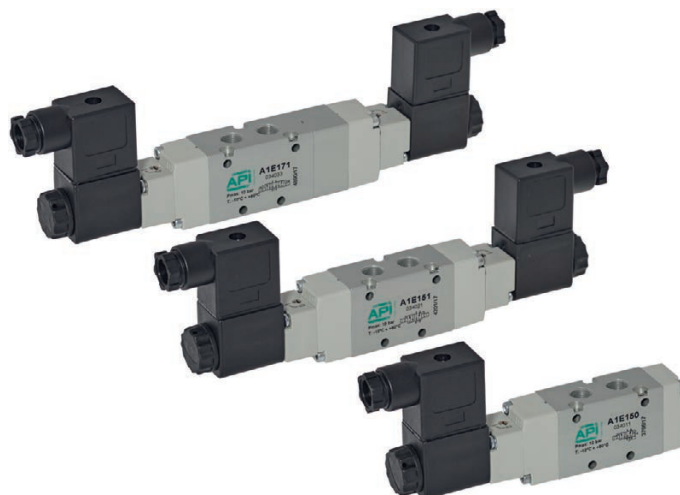

Series of spool valves, with static seals, high flow, for panel or sub-base mounting.

Coils and connectors have to be ordered separately.

For the coils type ASA12... see page 2.200.1

For the connectors type A122... see page 2.210.20

For the sub-bases type A1B1... see page 2.65.1

**Code key**

Series	Actuation	Size	Function	Options
A1	E = electrical K = electrical with external air pilot	1 = 1/8"	50 = 5/2 sol./spring 51 = 5/2 sol./sol. 70 = 5/3 CC 71 = 5/3 OC 72 = 5/3 PC	BT = low temp. seals

Options	Suffix
Low temperature seals (-25 ÷ +60°C)	<b>BT</b>

**II 2Gc IIB T5**  
**II 2Dc T100°C**

On request, they can be supplied according to 2014/34/EU - ATEX

**Technical data**

Fluid	Compressed filtered air with or without lubrication. Lubrication, if be used, must be continous.		
Pressure range	Spring return: 1,5 ÷ 10 bar	Bistable: 1 ÷ 10 bar	3 position: 2,5 ÷ 10 bar
Temperature range	-10°C ÷ +60°C (standard)		-25°C ÷ +60°C (BT)
Orifice	6,5 mm		
Flow	650 NI/min. at 6 bar with ΔP 1bar		
Minimum external air pressure	1,5 bar		
Mounting	In any position		
Manual override	Bistable		
Response time (at 6 bar)	solenoid/spring		solenoid/solenoid
	Energising: 35 ms	De-energising: 15 ms	Energising: 20 ms De-energising: 20 ms
Materials	Body:	Anodised aluminium	
	Covers:	Hostaform C 13031	
	Spool:	Hard aluminium anodized	
	Distancers:	Ixef 1022	
	Seals:	Hydrogenated Nitrile Butadiene Rubber (HNBR)	

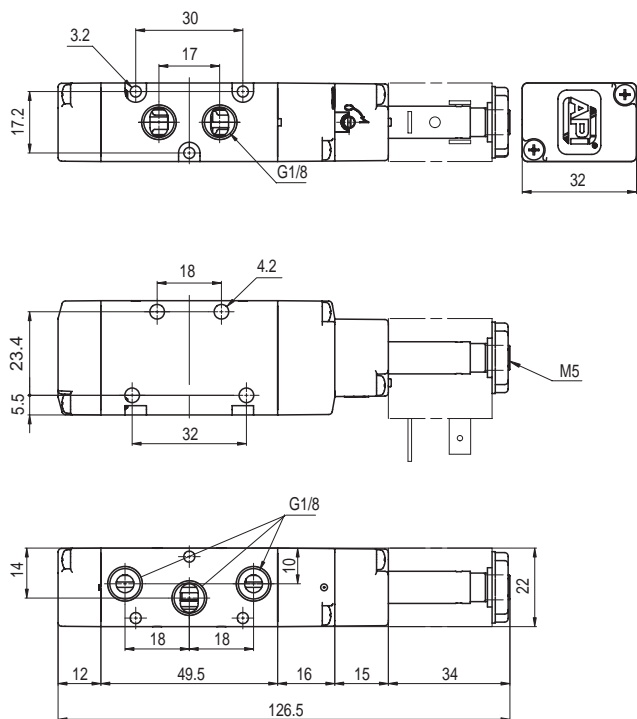

Version	Symbol	Code	Item
5/2 solenoid/spring		034011	A1E150

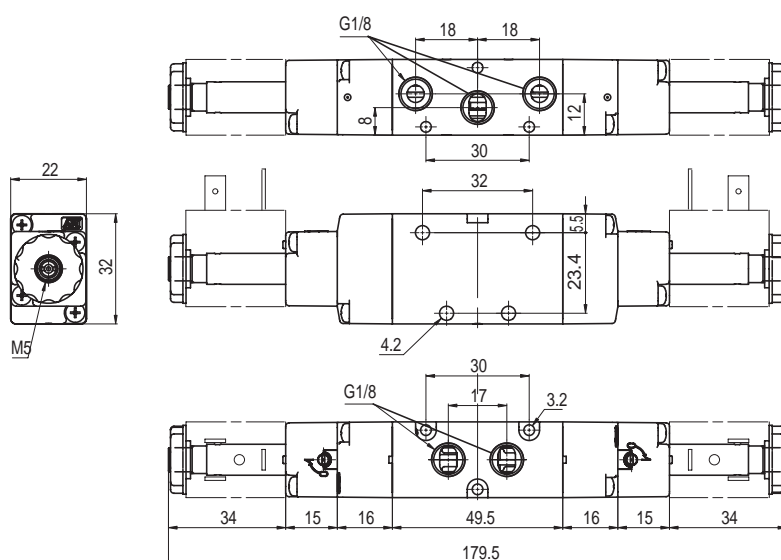

Version	Symbol	Code	Item
5/2 solenoid/solenoid		034021	A1E151

Version	Symbol	Code	Item
5/3 with closed centres		034031	A1E170
5/3 with open centres		034033	A1E171
5/3 with pressurised centers		034032	A1E172

Version	Symbol	Code	Item
5/2 solenoid/spring, external air pilot		034012	A1K150

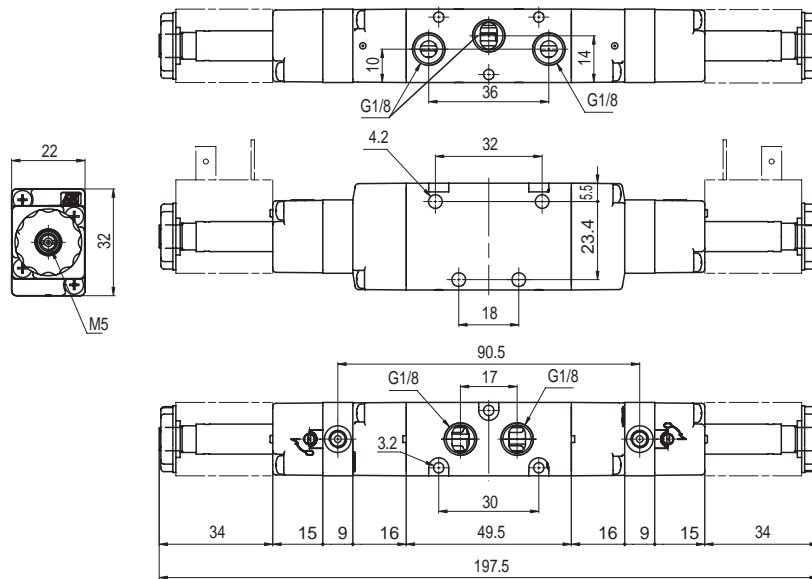

Version	Symbol	Code	Item
5/2 solenoid/solenoid external air pilot		034008	A1K151

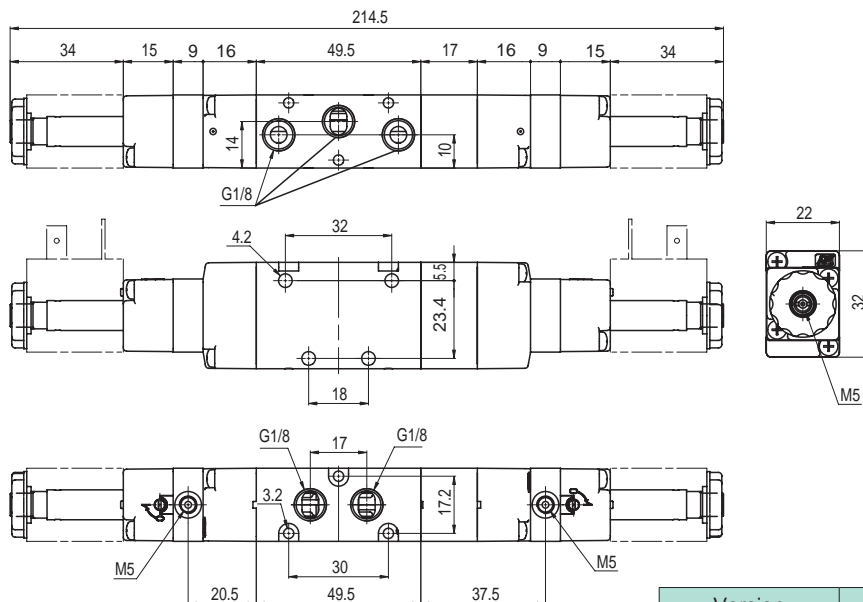

Version	Symbol	Code	Item
5/3 with closed centres, external air pilot		034009	A1K170
5/3 with open centres, external air pilot		034010	A1K171
5/3 with pressurised centers external air pilot		034013	A1K172